

JCB-WL-PALM

1000 LUMEN LED LIGHTWEIGHT WORKLIGHT / POWERBANK

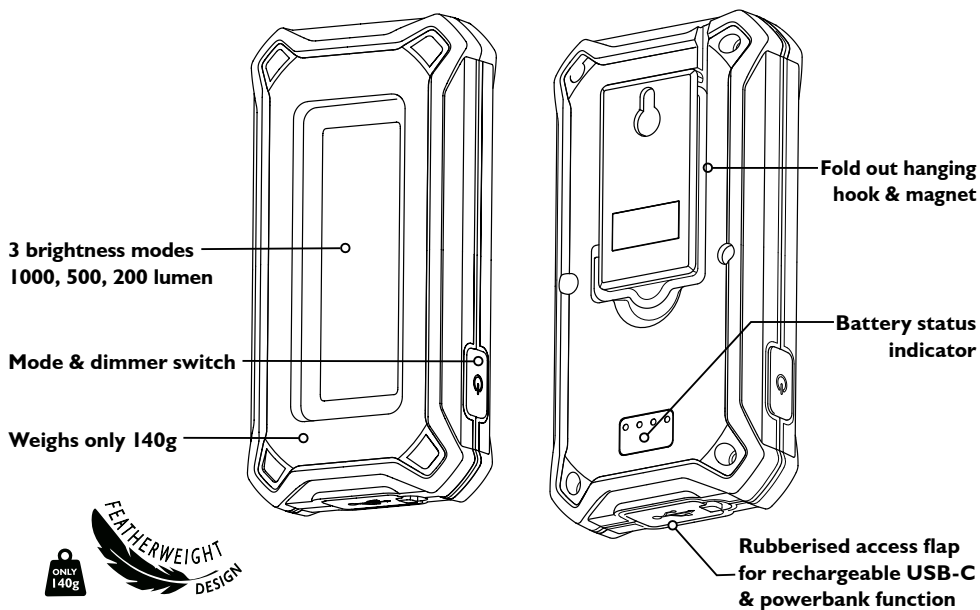

PRODUCT DESCRIPTION

Rechargeable slim palm size work light
Work light has 3 brightness modes 1000, 500, 200 lumen
Hanging hook and strong magnet on rear
Powerbank function to charge phones etc
Lightweight 140g
Battery status indicator
IP54 water and dustproof
USB-C charging

SPECIFICATION

Charging:	USB C
Battery:	3.7V 2500mAh Li-ion
Charge Time:	3.5h
Runtime:	Up to 11.5 hrs
Brightness:	1000 lumen
Colour Temperature:	6500K

BATTERY TREATMENT / CHARGING

Recharge when there is one indicator
Fully charged when indicator shows all bars are lit
Do not leave the battery fully discharged

OPERATION

Press the on/off switch once 1000 lumens
Press on/off switch twice 500 lumens
Press on/off switch three times 200 lumens
Press on/off switch four times off

SAFETY NOTICE

Prior to use carry out the necessary risk assessment considering the people who could be at risk, the level of risk and the precautions required to control the risk.

GENERAL

Ensure the worklight is correctly charged before initial use

DO NOT cover or block the lens during use

DO NOT shine the product directly into the eyes of people or animals

DO NOT allow children to use the worklight

DO NOT handle or move the worklight while it is being charged

DO NOT use the worklight if you suspect it is damaged

DO NOT place the product in or near naked flames

DO NOT open the equipment or touch any of the internal parts

DO NOT open the battery pack

DO ensure the worklight is unplugged and allow to cool before attempting cleaning and maintenance

BATTERY

WARNING! To reduce the risk of fire or burns:

DO NOT attempt to open, disassemble, modify or service the battery

DO NOT expose to temperatures below 10°C or above 40°C

DO NOT crush, puncture, short external contacts or dispose of in fire or water

DO NOT dispose of with regular waste - dispose of the old batteries in accordance with local authority battery regulations

DO NOT cover the battery while charging

Ensure the charger is switched off and disconnected from the worklight before attempting to open the lamp unit

If the electrolyte in the cells comes into contact with the skin, wash thoroughly with soap and water

If the electrolyte in the cells comes into contact with the eyes, rinse thoroughly with cold water and seek immediate medical attention

The worklight should be turned off during charging to prolong battery life



SAFETY NOTICE

ELECTRICAL

WARNING! It is the user's responsibility to read, understand and comply with the following electrical instructions:

Ensure the risk of electrical shock is minimised by the installation of appropriate safety devices

Inspect the charger cable and connection for wear and damage to ensure the items are safe before connecting to the mains power supply

DO NOT use if worn or damaged

Check cables are always protected against short circuit and overload

DO NOT place the connector into any area of the worklight except the correct outlet socket

DO NOT use the cable to charge or power any other electrical items

DO NOT wet the cable or use in wet or damp conditions (indoor use only)

MAINTENANCE & STORAGE

Keep the worklight clean from dirt and grease using a damp cloth

DO NOT submerge in water

DO NOT clean the worklight with solvents

DO check the product for damage before each use

If the product is not used for a long time, the battery will go into over discharge protection. To re-activate the battery, charge three or four times for 30 seconds until the indicator light comes on. Then fully charge the battery as normal.

GUARANTEE

This product is guaranteed against manufacturing defects for a period of 3 years from the date of purchase.

Repair or replacement of products will be undertaken providing that:

- The product has been subject to fair wear and tear only
- The product has not been subject to accidental or cosmetic damage
- The product has not been misused and has been used only in accordance with the instruction manual provided
- The product has not been subject to insufficient servicing and maintenance
- The product has not been subject to any abnormal environmental conditions or inappropriate operating conditions
- Repairs have not been attempted by an unauthorised person and no modifications have been made to the product

The guarantee excludes the following (where relevant):

- Components normally subject to wear and tear
- Batteries and chargers

Your statutory rights are not affected.

We reserve the right to alter specifications without prior notice

WE WILL NOT BE LIABLE FOR ANY INJURIES OR CONSEQUENTIAL DAMAGES RESULTING FROM THE USE OF THIS PRODUCT



GENERAL WARNINGS & DISPOSAL

This product has been marked with a symbol relating to removing electric and electronic waste. The product should not be discarded with household waste but must be returned to a collection system which conforms to the European Directive 2012/19/EU. It will then be recycled or dismantled in order to reduce the impact on the environment. Electric and electronic equipment can be hazardous for the environment and for human health since they contain hazardous substances.



www.jcbworklights.com | sales@jcbworklights.com

JCB Lighting is used under licence by Property Perspective Ltd

