

# JCB-SL-KONNECT 6500

## MAINS OR 18V DC BATTERY POWERED LIGHT

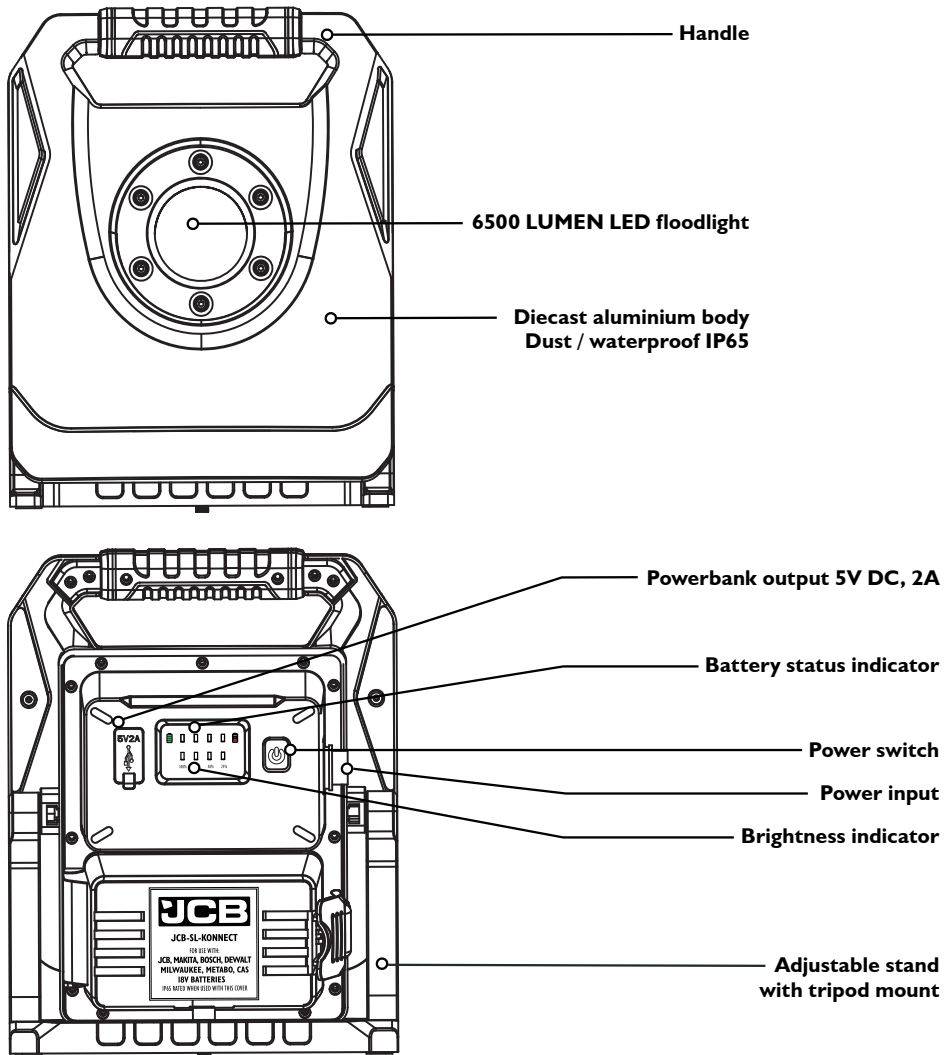

## PRODUCT DESCRIPTION

Mains / power tool battery site light  
Strong diecast aluminium body  
4 Light Settings 25%, 50%, 75%, 100%  
Adjustable tripod mountable stand  
LED battery status and brightness indicator  
Powerbank output 5V DC, 2A  
IP65 Water and dustproof with battery cover closed  
IK08 Drop tested

## SPECIFICATION

Mains input voltage:	AC 100 - 240V 50 / 60Hz 5 metre industrial quality mains cable fitted with 240V 13 Amp BS plug, 110V plug or 220/240V EU plug
Also powered by:	18V main brand power tool batteries
Connectors for:	JCB, DeWalt, Milwaukee, Bosch, Makita, Metabo, CAS
Output:	6500 lumens
Light source:	LED
Body composition:	Strong diecast aluminium
Colour Temperature:	6500K
Weight	2.35 kg

## OPERATION - USING MAINS CABLE

To operate using the mains cable supplied

Ensure that the cable is unplugged and not connected to the electricity source

Remove the plug cover A as shown in figure 1

Align the connector B with the socket A and push gently so that it locates and locks into place as shown in figure 2 AB

Turn on the electricity, switch on the light and use the brightness settings to get the level required

To remove turn the connector in the direction of the arrow shown twist and remove as per figure 2 AB after disconnecting from the electricity supply and replace the dust cover cap

The mains lead powers the light only and will not charge batteries

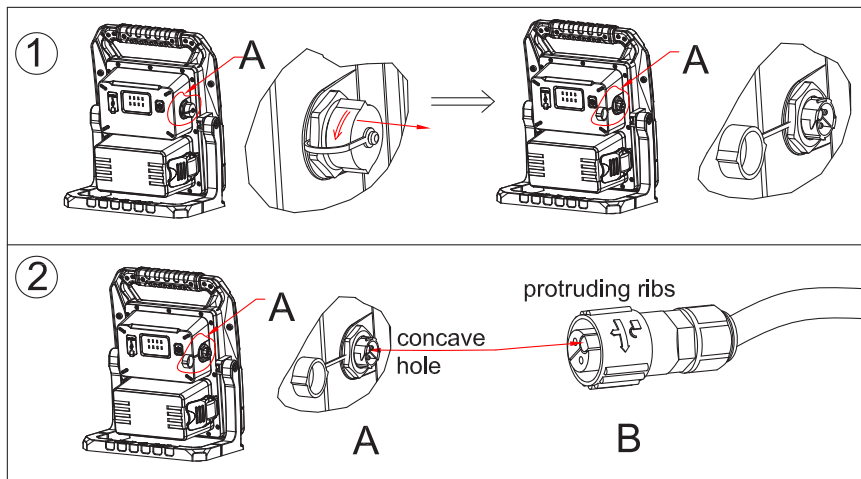

## OPERATION - USING 18V POWER TOOL BATTERIES

Release the battery cover latch and open as per diagram 1

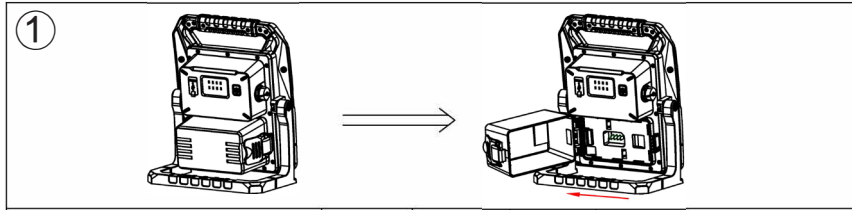

Insert the correct connector for the battery you are going to use and clip in place as per diagram 2 below

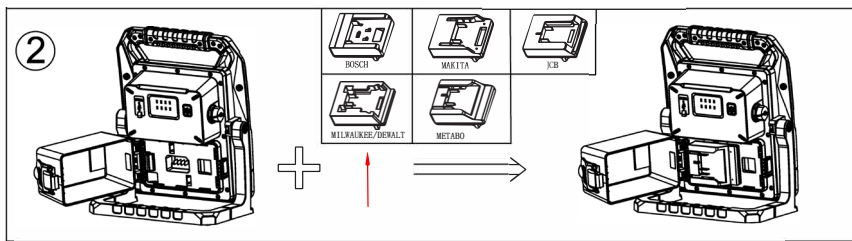

Slide the 18V battery onto the connector until it clicks in place as per diagram 3

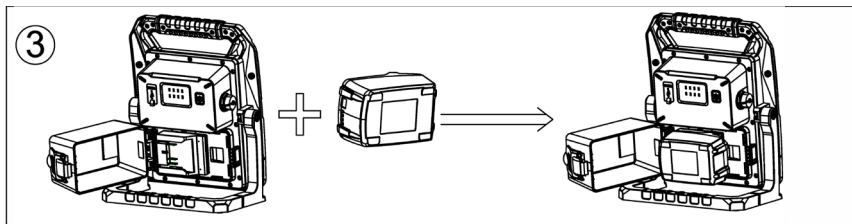

Close the battery cover and lock in place with the latch as per diagram 4 as below

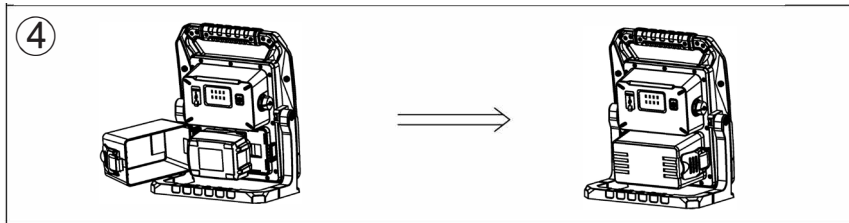

The light is now ready to use with the battery

The battery status indicator shows you how much power you have left in your battery

Press the on/off switch and set the light to the brightness level required

If you wish to remove the battery cover press together the 2 plastic tabs on the inside of the cover which locate the hinge pins and take the cover off

Reverse the above to re-attach the cover when required

## SAFETY NOTICE

Prior to use carry out the necessary risk assessment considering the people who could be at risk, the level of risk and the precautions required to control the risk.

### GENERAL

Ensure that the battery is correctly fitted before use

DO NOT Cover or block the lens during use

DO NOT shine the product directly into the eyes of people or animals

DO NOT allow children to use the worklight

DO NOT use the worklight if you suspect it is damaged

DO NOT place the product in or near naked flames

DO NOT open the light or touch any of the internal parts

Do ensure that the worklight is turned off and the 18V battery is removed before attempting cleaning and maintenance

### ELECTRICAL

DO NOT use if the battery case is showing signs of damage

DO NOT place the connector anywhere except the correct socket

DO NOT use if the mains cable is damaged in any way

## MAINTENANCE & STORAGE

Keep the worklight clean from dirt and grease using a damp cloth

DO NOT submerge the light in water

DO NOT clean the light with solvents

DO check the light for any signs of damage before use

## **GUARANTEE**

This product is guaranteed against manufacturing defects for a period of 3 years from the date of purchase.

Repair or replacement of products will be undertaken providing that:

- The product has been subject to fair wear and tear only
- The product has not been subject to accidental or cosmetic damage
- The product has not been misused and has been used only in accordance with the instruction manual provided
- The product has not been subject to insufficient servicing and maintenance
- The product has not been subject to any abnormal environmental conditions or inappropriate operating conditions
- Repairs have not been attempted by an unauthorised person and no modifications have been made to the product

The guarantee excludes the following (where relevant):

- Components normally subject to wear and tear
- Batteries and chargers

Your statutory rights are not affected

We reserve the right to alter specifications without prior notice

**WE WILL NOT BE LIABLE FOR ANY INJURIES OR CONSEQUENTIAL DAMAGES RESULTING FROM THE USE OF THIS PRODUCT**

## GENERAL WARNINGS & DISPOSAL

This product has been marked with a symbol relating to removing electric and electronic waste. The product should not be discarded with household waste but must be returned to a collection system which conforms to the European Directive 2012/19/EU. It will then be recycled or dismantled in order to reduce the impact on the environment. Electric and electronic equipment can be hazardous for the environment and for human health since they contain hazardous substances.



[www.jcbworklights.com](http://www.jcbworklights.com) | [sales@jcbworklights.com](mailto:sales@jcbworklights.com)

JCB Lighting is used under licence by Property Perspective Ltd

